

## Multiple combination

### minimax cu 410e F 27 TERSA

With TERSA knife shaft, tiltable milling spindle and format sliding carriage. Ideal for company carpentry, workshops and small businesses.



#### Article number ▼

5500550

#### Brand ▼

Holzkraft

#### Availability ▼

In stock  
Immediate delivery

#### Catalog directory ▼

Woodworking machinery » Multiple combinations » minimax cu e TERSA



#### Purchase ▼

Minimum 1 pc(s).

#### Shipping informations ▼

Packaging Metrics		Weights		Delivery		Other	
Length	n/a	Gross	857 kg	Delivery	Carrier	DualUse	✘
Width	n/a	Net	857 kg	Content	1 pc(s).	SCIP	n/a
Height	n/a					SVHC	No

#### Root data ▼

Country of origin	EAN	Custom number	Quantity unit
 Italy	4036351221371	84651010	pc(s).



MADE IN ITALY

#### Description ▼

- For sawing, milling, surface/thickness planing and optional slotted hole drilling in confined spaces
- High precisionziser format sliding carriage made of anodised aluminium, various lengths
- Large extension arm (1200 x 650 mm) with material roll and extendable aluminium telescopic stop up to max. 3200 mm with professional stop flaps
- Max. Saw blade Ø 315 mm, tiltable from 90° to -45°
- Large tilting range of the milling spindle from 90° to -45° backwards
- Four milling speeds up to 10000 min<sup>-1</sup> manually adjustable
- With right-left rotation of the milling spindle
- Heavily ribbed dressing work tables made of stress-free grey cast iron for decades of stability and flatness
- 2-stage feed for thickness planing
- Three independent industrial motors for continuous operation
- With lockablebare main switch, motor protection switch
- Standard with separate saw parallel fence and separate jointing fence for dressing
- Fixed handwheels

## Significant Features ▼



## Media informations ▼





**Trimming frame**

- With angle-adjustable telescopic crosscut fence
- With degree grid division



**Rip fence**

- With fine adjustment and quick tension
- Standard with stable round rod guide made of ground steel
- Conveniently hinged for cutting large workpieces
- Reversible aluminum ruler
- No dimension gap, guide rods are overlapping



**Aluminium sliding table**

- Equipped with ball contact system proven a thousand times over
- Runs on hardened and ground steel guides
- Torsion-resistant, high-precision, smooth-running and problem-free in daily use
- insensitive to dust and dirt due to minimal contact point between ball and trapezoidal rail
- 10 years wood strength guarantee on wear of the guideways



**Cast iron double weigh saw unit**

- Height adjustment via dovetail guide
- Extremely robust and torsion resistant for precise cuts
- Close to the saw blade, mounted on both sides
- Height and up to 45° adjustable
- lasting precision of the swivel due to double segment guide
- 6 years wood power guarantee on wear of the swivel segments
- Illustration shows optionally available scoring unit with drive via separate motor



**Milling unit with double support**

- Large-dimensioned swivelling milling unit with double support made of grey cast iron
- Fixing points directly on the table, thus optimum running smoothness
- Milling spindle high up with preprecision ball bearing mounted, thus low bearing load and highest possible service life
- lasting precision of the swivel due to double segment guide
- 6 years wood power guarantee on wear of the swivel segments



### Milling stop

- Heavy professional version
- The high-quality milling fence made of grey cast iron is supplied with fine adjustment as standard
- Triple positionable for quick resetting of the setting
- With fine adjustment via gear rack, numerical display and aluminium milling fence jaws



### Planing mills

- Helical toothed steel infeed rollers for a constant and even wood infeed
- Massive kick-back guards prevent the kick-back of workpieces
- 4-knife tershaft ensures an optimal planing pattern
- Table lips for quieter running



### TERSA planer cutterhead

- No more adjusting and screwing
- Change planing knives in seconds
- Self-locking
- Particularly low noise

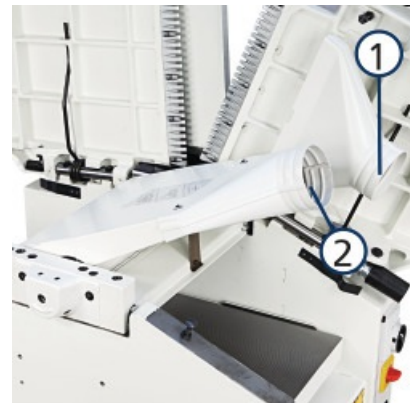

### Suction hose connection

- The suction connections of the dressing tools (1) and thicknesses (2) point in the same direction. The suction hose can therefore be fed to the machine from the same side for both applications. You do not need a hose that reaches around the machine.

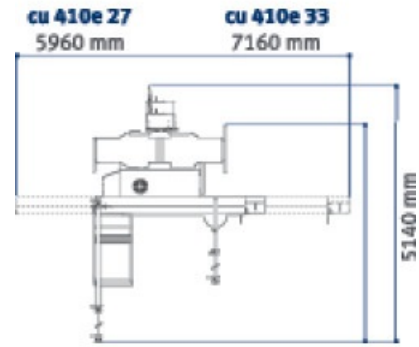

### Separate dressing stop

- Large professional version (1670 x 150 mm)
- 0-45° swivelling
- With quick adjustment
- Stable round rod guide made of ground steel

### Technical data ▼

Dimensions and weights			
Net weight approx.	857 kg		
Joining			
Infeed table width	410 mm	Infeed table length	2000 mm
Max. cutting depth of joints	5 mm		
Extraction port			
Extraction port diameter	3 x 120 mm	Saw blade protection extraction port diameter	60 mm
Footprint			
Space requirement length	5960 mm	Space requirement width/depth	5140 mm
Space requirement explanation	The dimensions take into account maximum travel distances or useful lengths.	Work area length	1600 mm
Work area width/depth	1600 mm	Explanation about work area	Please add the given dimensions with the required space to obtain the free space recommended for the machine.
Thickness			
Thickening table length	757 mm	Thickening table width	423 mm
Working height min. thickness	3 mm	Working height max. thickness	230 mm
Max. cutting depth thickness	5 mm		
Electrical Data			
Supply voltage	400 V	Mains frequency	50 Hz
Duty type drive motor	S6	Duty cycle drive motor	40 %
Drive motor output	3 x 5.0 kW		

Sliding carriage and table			
Sliding table length	2660 mm	Sliding table width	360 mm
Sliding table height	142 mm	Table length	1250 mm
Table width	430 mm	Table height	900 mm
Milling spindle			
Spindle angle	0 – -45 °	Mandrel diameter	30 mm
Usable spindle length	125 mm	Spindle speed(s)	3500/6000/8000/10000 min <sup>-1</sup>
Milling cutter diameter max.			
Max. tool diameter, lowerable	210 mm	Max. tool diameter, lowerable 45°	150 mm
Max. tool diameter pin milling	275 mm		
Planing knife shaft			
Planing shaft type	TERSA	Planing shaft diameter	87 mm
Number of planing blades	4 St	Planing shaft speed	5200 min <sup>-1</sup>
Circular saw unit			
Trimming length	2600 mm	Cutting width with rip fence	900 mm
Max. cross-cutting width left of saw blade	3260 mm	Saw blade angle	90 – 45 °
Max. cutting height at 90°	90 mm	Max. cutting height at 45°	63 mm
Max. saw blade protrusion 90°	100 mm	Max. saw blade protrusion 45°	71 mm
Diameter of (main) saw blade	315 mm	Explanation about diameter of (main) saw blade	with scorer
(Main) saw blade speed	4000 min <sup>-1</sup>		
Feed			
Feed speed	6 - 12 m/min		

## Equipment ▼

Scoring unit	optionally available	Sliding carriage	made of anodised aluminium
Handle for sliding carriage	✓	Trimming frame	✓
Material roll on the trimming frame	✓	Trimming shoe	✓
Eccentric clamp	✓	Mitre fence	with degree graduation and two professional folding stops
Saw parallel stop	<input type="checkbox"/> , with stable round rod guide	Dressing joint fence	✓
Curved milling protection hood	✓	Milling stop	with aluminium jaws and quick positioning
Height adjustment and tilting of the saw unit	manual	Height adjustment and swivelling of the milling unit	manual

## Accessories ▼



**Reversible planer knife**  
**Tersa 410 x 10 x 2.3 mm chrome (4 pieces)**  
Quality at reasonable prices



**Article number** ▼  
5270411

**Availability** ▼  
In stock  
Immediate delivery

**Purchase** ▼  
Minimum 1 Set (4 pc(s).)

**Price informations** ▼



### Reversible planer knife

#### Tersa 410 x 10 x 2.3 mm M+ HSS (4 pieces)

Quality at reasonable prices

**Article number** ▼  
5271411

**Availability** ▼  
In stock  
Immediate delivery

**Purchase** ▼  
Minimum 1 Set (4  
pc(s).)

**Price informations** ▼



### Replacement blade for spiral knife shaft

#### 15 x 15 x 2.5 mm

**Article number** ▼  
5514127

**Availability** ▼  
In stock  
Immediate delivery

**Purchase** ▼  
Minimum 1 PU (10  
pc(s).)

**Price informations** ▼



### Slot mortising equipment

#### LLBE-FS-ELITE / ELITE-S-CU-ELITE

**Article number** ▼  
5510418

**Availability** ▼  
No stock available  
Information:  
Next availability  
Unknown

**Purchase** ▼  
Minimum 1 pc(s).

**Price informations** ▼

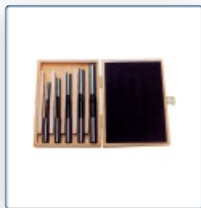

### Long hole drill set

#### 5-part, left-handed

**Article number** ▼  
5333681

**Availability** ▼  
In stock  
Immediate delivery

**Purchase** ▼  
Minimum 1 pc(s).

**Price informations** ▼



### Additional work table on the sledge

**Article number** ▼  
5510402

**Availability** ▼  
In stock  
Immediate delivery

**Purchase** ▼  
Minimum 1 pc(s).

**Price informations** ▼

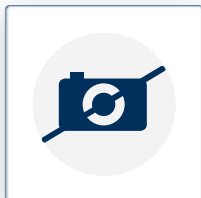

### Milling cutter with protective cover

#### for tools Ø 275 mm

**Article number** ▼  
5510407

**Availability** ▼  
No stock available  
Information:  
Next availability  
Unknown

**Purchase** ▼  
Minimum 1 pc(s).

**Price informations** ▼







### Travelling device



**Article number** ▼  
5514108

**Availability** ▼  
No stock available  
Information:  
Next availability  
Expected on  
calendar week  
49/2023

**Purchase** ▼  
Minimum 1 pc(s).

**Price informations** ▼



### Mitre fence 1060 mm, with telescopic guide



**Article number** ▼  
5514315

**Availability** ▼  
No stock available  
Information:  
Next availability  
Unknown

**Purchase** ▼  
Minimum 1 pc(s).

**Price informations** ▼

## Options equipment ▼



### Pre-cutting device with saw blade 100 mm



**Article number** ▼  
5510406

**Availability** ▼  
No stock available  
Information:  
Next availability  
Unknown

**Purchase** ▼  
Minimum 1 pc(s).

**Price informations** ▼



### Pre-cutting device with separate motor, saw blade 100 mm



**Article number** ▼  
5510405

**Availability** ▼  
No stock available  
Information:  
Next availability  
Unknown

**Purchase** ▼  
Minimum 1 pc(s).

**Price informations** ▼



### Swivel arm for feed unit



**Article number** ▼  
5510510

**Availability** ▼  
No stock available  
Information:  
Next availability  
Expected on  
calendar week  
48/2023

**Purchase** ▼  
Minimum 1 pc(s).

**Price informations** ▼



## Spiral blade shaft SMW 410 elite



**Article number** ▼

5510433

**Availability** ▼

No stock available  
Information:  
Next availability  
Unknown

**Purchase** ▼

Minimum 1 pc(s).

**Price informations** ▼

Prices on this data sheet are recommended retail prices, subject to change, in €, plus VAT at the statutory rate, plus packaging, shipping, transport, unloading, assembly and, if applicable, instruction costs. Sales prices of the dealers can deviate. No liability is accepted for printing errors, mistakes or incorrect presentation. Technical and optical changes are reserved. Illustration partly with optional accessories.