

Universal grinding machine

OPTIgrind GU 25S

Functional with abrasive attachment

OPTIMUM[®]
MASCHINEN - GERMANY

Article number ▼

3101580

Brand ▼

Optimum

Availability ▼

In stock

Immediate delivery

Catalog directory ▼

Metalworking machines » Grinding and polishing machines for metal » Universal grinding machines with grinding attachment

Purchase ▼

Minimum 1 pc(s).

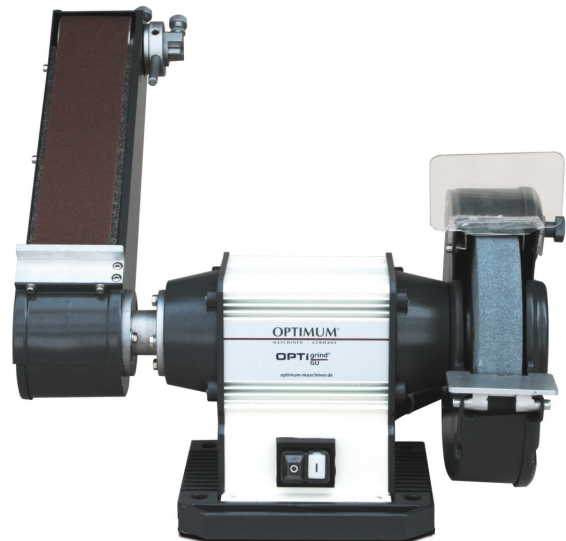

Delivery content ▼

- Grinding wheel normal corundum fine K80
- Sanding belt normal corundum fine K80

Shipping informations ▼

Packaging Metrics		Weights		Delivery		Other	
Length	665 mm	Gross	34.5 kg	Delivery	Carrier	DualUse	✘
Width	577 mm	Net	31.5 kg	Content	1 pc(s).	SCIP	n/a
Height	382 mm					SVHC	No

Root data ▼

Country of origin	EAN	Custom number	Quantity unit
 China	4030635028892	84602990	pc(s).



Description ▼

- Robust and stable universal grinding machines with abrasive belt and grinding wheel for a wide range of materials
- Heavy, durable industrial design with maintenance-free motor
- Housing made of extruded aluminum
- Large, heavy mounting flanges and thus high disc concentricity
- Sanding attachment with graphite coating; prevents friction and heat
- Stop allows quick and easy sanding of workpieces
- Tape adjustment without tools - only adjustable with a handle screw
- Universal corundum grinding wheel and sanding belt in the standard scope of delivery

Workpiece support

- Stable
- Adjustable

Media informations ▼



Figure shows GU 20S

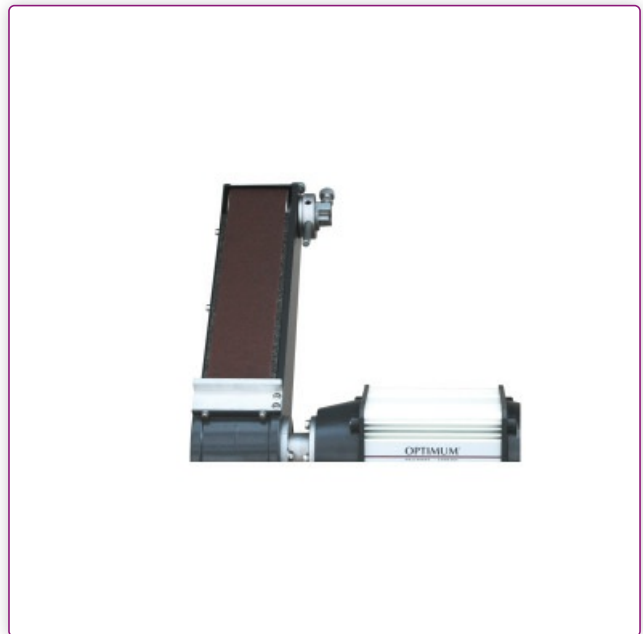

Sanding belt

- Grinding attachment can be adjusted via the flange in a swivel range of 0°-90





Grinding wheel

- Stable workpiece support surface
- Adjustable spark protection

Technical data ▼

Dimensions and weights			
Length (product) approx.	514 mm	Width/depth (product) approx.	319 mm
Height (product) approx.	596 mm	Net weight approx.	31.5 kg
Electrical Data			
Drive motor output	1,5 kW	Supply voltage	400 V
Mains frequency	50 Hz		
Grinding wheel(s)			
Grinding disc external diameter	250 mm	Grinding disc width	40 mm
Grinding disc drill hole	32 mm	Speed	2850 min ⁻¹
Sanding attachment			
Grinding belt length	1016 mm	Grinding belt width	75 mm
Grinding attachment swivel range	90 °	Extraction duct nominal width	32 mm
Grinding support length	305 mm	Grinding support width	87 mm

Accessories ▼

	<p>Substructure GU 3</p> <p>Article number ▼ 3107118</p> <p>Availability ▼ In stock Immediate delivery</p> <p>Purchase ▼ Minimum 1 pc(s).</p> <p>Price informations ▼</p>	
---	---	---



Wall bracket for OPTIgrind QSM 150 to SM 250

Article number ▼
3107050

Availability ▼
In stock
Immediate delivery

Purchase ▼
Minimum 1 pc(s).

Price informations ▼

OPTIMUM[®]
MASCHINEN - GERMANY



Machine substructure with extraction GU 1 (400 V)

Integrated cyclone extraction with automatic switch

Article number ▼
3107109

Availability ▼
In stock
Immediate delivery

Purchase ▼
Minimum 1 pc(s).

Price informations ▼

OPTIMUM[®]
MASCHINEN - GERMANY

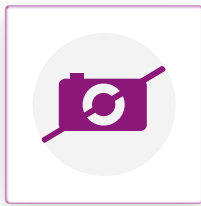

Fabric grinding belt for steel, stainless steel, non-ferrous metals 75 x 1016 mm P40

Article number ▼
3357682

Availability ▼
In stock
Immediate delivery

Purchase ▼
Minimum 1 PU (5
pc(s).)

Price informations ▼

OPTIMUM[®]
MASCHINEN - GERMANY

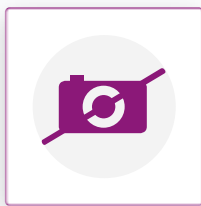

Fabric grinding belt for steel, stainless steel, non-ferrous metals 75 x 1016 mm P60

Article number ▼
3357684

Availability ▼
In stock
Immediate delivery

Purchase ▼
Minimum 1 PU (5
pc(s).)

Price informations ▼

OPTIMUM[®]
MASCHINEN - GERMANY

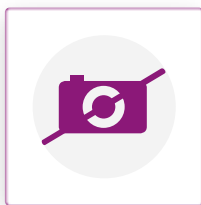

Fabric grinding belt for steel, stainless steel, non-ferrous metals 75 x 1016 mm P80

Article number ▼
3357686

Availability ▼
In stock
Immediate delivery

Purchase ▼
Minimum 1 PU (5
pc(s).)

Price informations ▼

OPTIMUM[®]
MASCHINEN - GERMANY

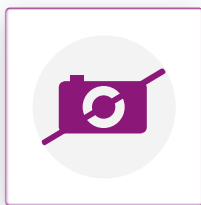

Fabric grinding belt for steel, stainless steel, non-ferrous metals 75 x 1016 mm P120

Article number ▼
3357688

Availability ▼
In stock
Immediate delivery

Purchase ▼
Minimum 1 PU (5
pc(s).)

Price informations ▼

OPTIMUM[®]
MASCHINEN - GERMANY



Fabric grinding belt for steel, stainless steel, non-ferrous metals

75 x 1016 mm P180

Article number ▼
3357689

Availability ▼
In stock
Immediate delivery

Purchase ▼
Minimum 1 PU (5 pc(s).)

Price informations ▼

OPTIMUM®
MASCHINEN - GERMANY

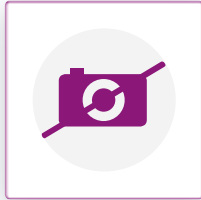

Fabric grinding belt for steel, stainless steel, non-ferrous metals

75 x 1016 mm P240

Article number ▼
3357690

Availability ▼
In stock
Immediate delivery

Purchase ▼
Minimum 1 PU (5 pc(s).)

Price informations ▼

OPTIMUM®
MASCHINEN - GERMANY



Normal corundum grinding wheel

Ø 250 x 40 Ø 32 mm, K36

Article number ▼
3107250

Availability ▼
In stock
Immediate delivery

Purchase ▼
Minimum 1 pc(s).

Price informations ▼

OPTIMUM®
MASCHINEN - GERMANY



Normal corundum grinding wheel

Ø 250 x 40 Ø 32 mm, K80

Article number ▼
3107255

Availability ▼
In stock
Immediate delivery

Purchase ▼
Minimum 1 pc(s).

Price informations ▼

OPTIMUM®
MASCHINEN - GERMANY

Options equipment ▼



Vario conversion with machine base

GU 3 - 1.5 kW

Enables the speed of the grinder to be controlled steplessly

Article number ▼
3491531

Availability ▼
In-house production
- available at short notice

Purchase ▼
Minimum 1 pc(s).

Price informations ▼

OPTIMUM®
MASCHINEN - GERMANY



Vario conversion with machine base

GU 1 - 1.5 kW

With cyclone suction. Enables the speed of the grinder to be infinitely variable

Article number ▼
3491530

Availability ▼
In-house production
- available at short notice

Purchase ▼
Minimum 1 pc(s).

Price informations ▼

OPTIMUM®
MASCHINEN - GERMANY

Prices on this data sheet are recommended retail prices, subject to change, in €, plus VAT at the statutory rate, plus packaging, shipping, transport, unloading, assembly and, if applicable, instruction costs. Sales prices of the dealers can deviate. No liability is accepted for printing errors, mistakes or incorrect presentation. Technical and optical changes are reserved. Illustration partly with optional accessories.