

Radial drill

OPTIdrill RD 5

Precision-working, solid radial drilling machines in top quality. Ideal for variable use in single part and series production.

OPTIMUM[®]
MASCHINEN - GERMANY

Article number ▾

3049050

Brand ▾

Optimum

Availability ▾

In stock

Availability on request

Catalog directory ▾

Metalworking machines » Drilling machines
» Radial drilling machines » OPTIdrill RD

Purchase ▾

Minimum 1 pc(s).



Delivery content ▾

- worktable

Shipping informations ▾

Packaging Metrics		Weights		Delivery		Other	
Length	1,880 mm	Gross	1,950 kg	Delivery	Special transportation	DualUse	✘
Width	860 mm	Net	1,800 kg	Content	1 pc(s).	SCIP	n/a
Height	2,210 mm					SVHC	No

Root data ▾

Country of origin	EAN	Custom number	Quantity unit
 Taiwan	4030635033391	84592900	pc(s).

Video ▾

www.youtube.com/watch?v=pDjksNeuCys



Description ▼

- Versatile application, such as Drilling, rubbing, tapping
- Electrically braked engine
- 24V DC electrics and 2-channel safety chain according to DIN EN 12717
- Heavy, massive, high quality quality casting
- Wide reach through horizontally adjustable machine head
- Clearly arranged control panel
- Smooth-running swivel and travel axes
- Elaborately machined column pivoting with optimized clamping for maximum stability with minimum clamping offset
- Robust, rigid construction of the boom
- Height adjustment of the boom via powerful motor drive and lifting spindle
- In oil bath running gear of the drill head
- Boom guideways hardened and precision ground
- Geared gears made of chrome-nickel-steel, hardened and precision ground, thus quiet and smooth running
- Drilling head and column can be clamped or loosened together or separately
- Forward and reverse running
- Massive, exact drill table, large dimensions
- Hardened and ground worktable with parallel T-slots
- machine light
- Overload protection
- Thick-walled cast-iron column ensures smooth running and stability
- led lamp
- Coolant device with coolant tank in the machine foot

RD 4 / RD 5

- All axes are clamped manually

Media informations ▼

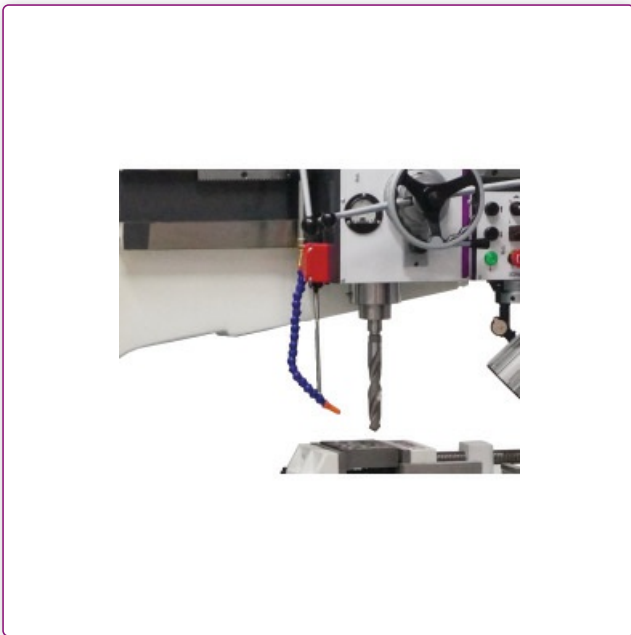

Figure shows RD 5 with optional drill and vice



DC control cabinet

- All contactors and relays from Siemens and Schneider
- Complete and clear



Extendable safety switch

- Compliant with DIN 12717



Column pivoting

- Elaborately crafted column swivel with optimized clamping for maximum stability with minimal clamping offset

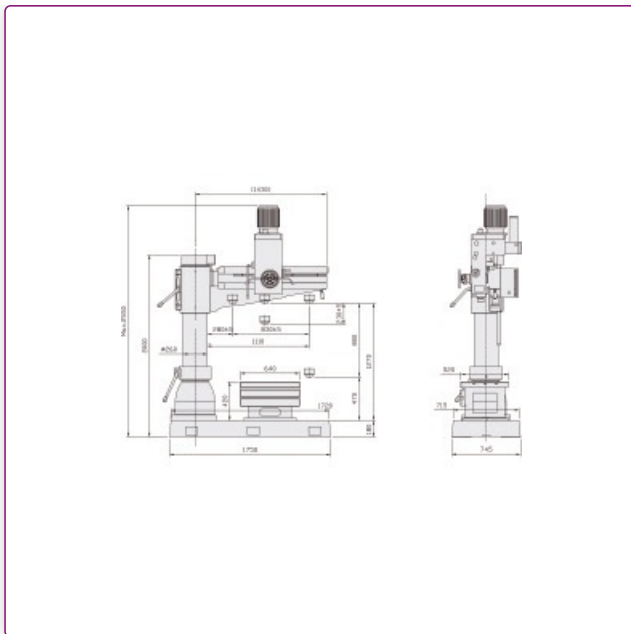













Technical data ▼

Dimensions and weights			
Column diameter	260 mm	Length (product) approx.	1725 mm
Width/depth (product) approx.	745 mm	Height (product) approx.	2550 mm
Net weight approx.	1800 kg		
Boom			
Boom angle of rotation	± 180 °		
Drilling performance			
Drilling performance steel (S235JR)	42 mm	Continuous drilling performance steel (S235JR)	40 mm
Drilling table			
Drilling table T-groove size	19 mm	Drilling table T-groove number	3
Drilling table T-groove spacing	171 mm	Max. distance spindle - drilling table	1270 mm
Clamping table length	635 mm	Clamping table width	520 mm
Clamping table height	415 mm	Cube table T-groove size	19 mm
Cube table T-groove number	3	Cube table T-groove spacing	121 mm
Min. distance spindle to clamping table	50 mm	Max. distance spindle to clamping table	850 mm
Min. distance spindle - drilling table	470 mm		
Speed range			
Speed range	37 – 1253 min ⁻¹	Number of gears	12
Electrical Data			
Total rated value	4 kW	Supply voltage	400 V
Mains frequency	50 Hz		
Machine base			
Machine base workspace length	1147 mm	Machine base workspace width	589 mm
Machine base length	1608 mm	Machine base width	745 mm
Spindle			
Quill stroke	230 mm	Spindle chuck	MT4
Quill feed speed	0.05 – 0.15 mm/rev	Quill feed gears	3
Travel			
Travel X axis manual	820 mm	Travel Z axis manual	570 mm

Max. distance spindle - column	1100 mm	Min. distance spindle - column	280 mm
Motor(s)			
Spindle motor drive output	2.25 kW	Boom lift motor drive output	0,75 kW
Coolant pump drive motor output	90 W		

Accessories ▼

	<p>Precision quick-action drill chuck 1-10 mm, B16</p>		
<p>Article number ▼ 3050610</p>	<p>Availability ▼ In stock Immediate delivery</p>	<p>Purchase ▼ Minimum 10 pc(s).</p>	<p>Price informations ▼</p>
	<p>Keyless drill chuck DKC13 0-13 mm</p>		
<p>Article number ▼ 3050632</p>	<p>Availability ▼ In stock Immediate delivery</p>	<p>Purchase ▼ Minimum 1 pc(s).</p>	<p>Price informations ▼</p>
	<p>Keyless drill chuck DKC16 0-16 mm</p>		
<p>Article number ▼ 3050633</p>	<p>Availability ▼ In stock Immediate delivery</p>	<p>Purchase ▼ Minimum 1 pc(s).</p>	<p>Price informations ▼</p>
	<p>OPTIMUM direct quick-action drill chuck MK 4 1 - 16 mm; up to 6000 min⁻¹</p>		
<p>Article number ▼ 3050574</p>	<p>Availability ▼ In stock Immediate delivery</p>	<p>Purchase ▼ Minimum 10 pc(s).</p>	<p>Price informations ▼</p>
	<p>Morse taper MK4-B16</p>		
<p>Article number ▼ 3050661</p>	<p>Availability ▼ In stock Immediate delivery</p>	<p>Purchase ▼ Minimum 1 pc(s).</p>	<p>Price informations ▼</p>
	<p>Reducing sleeve MK4-MK3</p>		
<p>Article number ▼ 3050664</p>	<p>Availability ▼ In stock Immediate delivery</p>	<p>Purchase ▼ Minimum 1 pc(s).</p>	<p>Price informations ▼</p>



Twist drill HSS with Morse taper MT 3

OPTIMUM[®]
MASCHINEN - GERMANY

Article number ▼
3051003

Availability ▼
In stock
Immediate delivery

Purchase ▼
Minimum 1 pc(s).

Price informations ▼



Down device Table groove 18 mm / M 16

OPTIMUM[®]
MASCHINEN - GERMANY

Article number ▼
3352032

Availability ▼
In stock
Immediate delivery

Purchase ▼
Minimum 1 pc(s).

Price informations ▼



Clamping tool kit SPW 16

OPTIMUM[®]
MASCHINEN - GERMANY

Article number ▼
3352019

Availability ▼
No stock available
Information:
Next availability
Unknown

Purchase ▼
Minimum 1 pc(s).

Price informations ▼
Revoked article



Clamping table 635 x 520 x 415 mm

OPTIMUM[®]
MASCHINEN - GERMANY

Article number ▼
3049205

Availability ▼
No stock available
Information:
Next availability
Unknown

Purchase ▼
Minimum 1 pc(s).

Price informations ▼



Angle table S

OPTIMUM[®]
MASCHINEN - GERMANY

Article number ▼
3049210

Availability ▼
No stock available
Information:
Next availability
Unknown

Purchase ▼
Minimum 1 pc(s).

Price informations ▼



Angle table L

OPTIMUM[®]
MASCHINEN - GERMANY

Article number ▼
3049212

Availability ▼
No stock available
Information:
Next availability
Unknown

Purchase ▼
Minimum 1 pc(s).

Price informations ▼

Prices on this data sheet are recommended retail prices, subject to change, in €, plus VAT at the statutory rate, plus packaging, shipping, transport, unloading, assembly and, if applicable, instruction costs. Sales prices of the dealers can deviate. No liability is accepted for printing errors, mistakes or incorrect presentation. Technical and optical changes are

reserved. Illustration partly with optional accessories.