

Precision guide and drawbar turning machine

OPTIturn TH 4610D

Precision guide and traction spindle lathes - unique in precision and operation.
With digital position indicator DPA 21 and quick-change steel holder

OPTIMUM[®]
MASCHINEN - GERMANY

Article number ▼

3462110

Brand ▼

Optimum

Catalog directory ▼

Metalworking machines » Lathes
conventional » OPTIturn TH 4610D / TH
4615D / TH 4620D

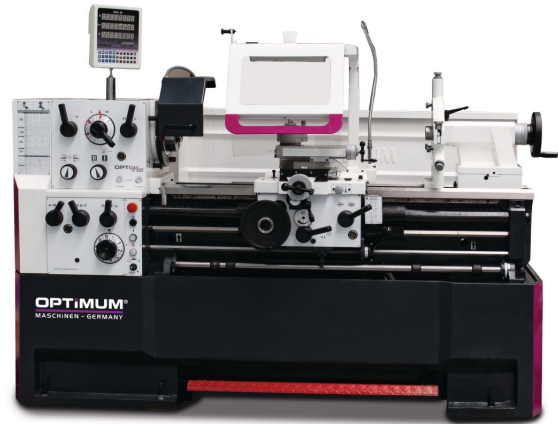

Shipping informations ▼

Packaging Metrics		Weights		Delivery		Other	
Length	2,280 mm	Gross	1,910 kg	Delivery	Special transportation	DualUse	✘
Width	1,150 mm	Net	1,645 kg	Content	1 pc(s).	SCIP	n/a
Height	1,650 mm					SVHC	No



Description ▼

- Hardened and ground Z-axis guideway
- Precisely crafted sled
- Handwheels with adjustable fine scale 0.04 / 0.02 mm
- Quadruple tool holder
- All guides can be adjusted by wedge strips
- Waves, wheels and main spindle running in oil bath
- Adjustment range upper slide $\pm 90^\circ$
- Guaranteed concentricity of the spindle nose better than 0.015 mm
- Gear wheels smooth, hardened and ground with 2 adjustable precision tapered roller bearings
- Fast-switching feed gear in a closed design, gears and shafts hardened and ground in an oil bath in precision bearings running
- Handwheels decoupled and tested according to EN 23125
- Two-channel right-left switch tested to EN 23125
- Switch with life cycle calculation, tested according to EN ISO 13849
- Right / left rotation on bed carriage via switching spindle switchable
- Mechanical longitudinal feed-out shut-off of the bed carriage with four adjustable eccentrics leading spindle
- Emergency stop device with foot control
- Safety handwheels with release function in the X and Z axis
- Adjustable scale of the threaded clock
- Central lubrication in the bed slide
- Tailstock for taper turning ± 10 mm adjustable
- Tailstock quill and hand wheel with adjustable fine scale 0.025 mm
- Fast, easy and tool-free adjustment by means of a clamping lever
- Strongly ribbed prism bed, induction hardened and precision ground from gray cast iron
- Coolant device with separate coolant tank with level indicator and oil separator; easy and complete emptying and cleaning according to DIN
- Large dimensioned chip guard with integrated LED machine lamp
- Quick change steel holder SWH 5-B

Delivery content ▼

- Fixed bezel passage max. \varnothing 160 mm
- Running bezel passage max. \varnothing 100 mm
- LED machine light
- Reduction sleeve MK 6 / MK 4
- Fixed centering point MK 4
- Quick change steel holder 5-B
- Steel holder 25 x 120 type D for square chisels 20 mm
- Threading gauge
- Change gear set
- Initial machine filling with quality oil
- Operating tool

Do not forget the lathe chuck!

Media informations ▼



Figure shows OPTiturn TH 4615 with optional quality chuck from OPTIMUM



Control cabinet

- 24 Volt DC power supply unit
- All contactors and relays from Siemens or Schneider



Dig. position indicator DPA 21

- User-friendly membrane keypad
- Significant reduction of production times
- Sensor for recording the spindle speeds



Quick-change steel holder SWH 5-B

- in standard scope of delivery
- Steel holder 25 x 120 type D for square chisel 25 mm in standard scope of delivery

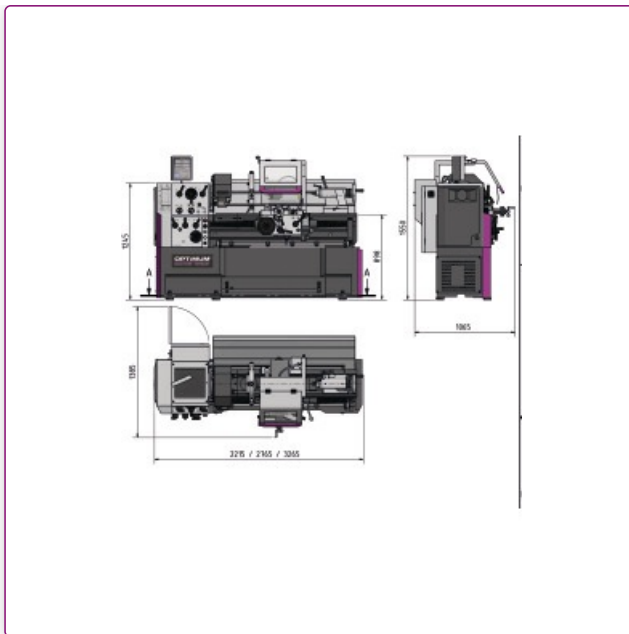

Technical data ▼

Dimensions and weights			
Length (product) approx.	2215 mm	Width/depth (product) approx.	1065 mm
Height (product) approx.	1550 mm	Net weight approx.	1645 kg
Work areas			
Max. height	230 mm	Max. width	1060 mm
Swing diameter above machine bed	460 mm	Swing diameter in bed bridge	690 mm
Swing diameter above planing slide	270 mm	Turning length in bed bridge	240 mm
Bed width	300 mm		
Speed range			
Number of gears	12	Speed range	25 – 2000 min ⁻¹
Electrical Data			
Drive motor output	5.5 kW	Supply voltage	400 V
Mains frequency	50 Hz		
Cooling lubricant system			
Cooling lubricant system coolant pump output	125 W		
Spindle			
Spindle chuck	Camlock DIN ISO 702-2 No. 6	Spindle bore/rod passage diameter	58 mm
Spindle cone	MT 6	Tool holder max. chuck height	25 mm
Tailstock			
Tailstock chuck	MT 4	Tailstock quill stroke	130 mm
Tailstock quill diameter	60 mm		
Pitches			
Metric pitch	0,1 – 14 mm/rev	Number of metric pitches	41
Imperial pitch	112 – 2 Gg/1"	Number of imperial pitches	41
Diametrical pitch	4 – 112 DPI	Number of diametrical pitches	50
Modular thread pitch	0,1 – 7 mm/rev	Number of modular thread pitches	34
Travel			
Travel upper slide	125 mm	Travel cross slide	285 mm
Travel carriage saddle	755 mm		

Feed			
Longitudinal feed range	0,031 – 1,7 mm/rev	Number of longitudinal feeds	42
Flat feed range	0,014 – 0,784 mm/rev	Number of flat feeds	42
Electrical connections			
Total rated value	5.8 kW		

Accessories ▼



Spare steel holder 25 x 120 type D

Article number ▼
3384306

OPTIMUM®
MASCHINEN - GERMANY



Spare steel holder 32 x 130 type H

Article number ▼
3384324

OPTIMUM®
MASCHINEN - GERMANY



Turning tool set HM 20 mm, 5-part

Article number ▼
3441670

OPTIMUM®
MASCHINEN - GERMANY



Turning tool set HM 20 mm, 5-part

Article number ▼
3441617

OPTIMUM®
MASCHINEN - GERMANY



Face plate Ø 350 mm Camlock DIN ISO 702-2 No. 6

Article number ▼
3442980

OPTIMUM®
MASCHINEN - GERMANY



Collet set
SPC 5C

Article number ▼
3441509

OPTIMUM[®]
MASCHINEN - GERMANY



Collet chuck
5C - No. 6

Article number ▼
3441556

OPTIMUM[®]
MASCHINEN - GERMANY



Position stop

Article number ▼
3444022

OPTIMUM[®]
MASCHINEN - GERMANY



OPTIMUM Three-jaw lathe chuck centre clamping
Ø 250 mm Camlock DIN ISO 702-2 No. 6

Article number ▼
3442765

OPTIMUM[®]
MASCHINEN - GERMANY



OPTIMUM four-jaw lathe chuck Cast Camlock, centre clamping
Ø 250 mm Camlock DIN ISO 702-2 No. 6

Article number ▼
3442852

OPTIMUM[®]
MASCHINEN - GERMANY



BISON three-jaw lathe chuck Camlock casting centre clamping
Ø 250 mm Camlock DIN ISO 702-2 No. 6

Article number ▼
3450330

OPTIMUM[®]
MASCHINEN - GERMANY



BISON four-jaw lathe chuck Cast Camlock centric exciting

Ø 250 mm Camlock DIN ISO 702-2 No. 6

Article number ▼
3450380

OPTIMUM®
MASCHINEN - GERMANY



**Turning tool set
HM 25 mm, 5-part**

Article number ▼
3441672

OPTIMUM®
MASCHINEN - GERMANY



**Turning tool set
HM 25 mm, 5-part**

With carbide inserts

Article number ▼
3441623

OPTIMUM®
MASCHINEN - GERMANY



**Internal turning set
5-piece**

Article number ▼
3441650

OPTIMUM®
MASCHINEN - GERMANY



**Center drill set
10tlg. 0.75-4.5 mm HSS**

Article number ▼
3203010

OPTIMUM®
MASCHINEN - GERMANY



**Clamping block set for lathes
20-05**

Article number ▼
3440654

OPTIMUM®
MASCHINEN - GERMANY



**Revolving centering point
MT 4**

Article number ▼
3440704

OPTIMUM®
MASCHINEN - GERMANY



Revolving centering point

MT 4

Article number ▼

3440734

OPTIMUM®
MASCHINEN - GERMANY



Revolving centering point

MT 4

Article number ▼

3451004

OPTIMUM®
MASCHINEN - GERMANY



Leveling plate

SE 3

Article number ▼

3381018

OPTIMUM®
MASCHINEN - GERMANY



Vibration damper machine foot

SE 85

Article number ▼

3352982

OPTIMUM®
MASCHINEN - GERMANY