

Universal drilling-milling machine

OPTImill MT 50 E

Universal boring milling machine with automatic table feed in the X and Y axis

Article number ▼

3336010

Brand ▼

Optimum

Catalog directory ▼

Metalworking machines » Milling machines
conventional » OPTImill MT 50E

OPTIMUM[®]
MASCHINEN - GERMANY



Shipping informations ▼

Packaging Metrics		Weights		Delivery		Other	
Length	1,380 mm	Gross	840 kg	Delivery	Carrier	DualUse	✘
Width	1,220 mm	Net	760 kg	Content	1 pc(s).	SCIP	n/a
Height	2,100 mm					SVHC	No



Description ▼

- Vibration-absorbing cast execution
- Easy-to-use control panel
- led lamp
- Milling head can be swiveled 45 ° to the left and right
- Automatic feed of the X and Y axes with speed adjustment
- Automatic and adjustable limit stop of the X-axis
- Mechanical Spindle sleeve for drilling over quill lever
- Oil bath gearbox with ground, hardened gear wheels
- Forward / reverse operation
- Coupling for switching from manual coarse feed to manual fine feed
- Large projection of the Y-axis spindle head carrier from 250 - 650 mm
- Exact cross table, large dimensioned and precisely surface-finished with adjustable wedges
- Height-adjustable protective screen with micro-switch, against flying chips and parts, for maximum protection of the user
- Massive and large-dimensioned XY stage with dovetail guides, precisely surface-finished with T-slots and adjustable wedges, swiveling $\pm 45^\circ$
- Coolant system

Delivery content ▼

- Geared chuck 3 - 16 mm / B 18
- Mandrel Drill chuck ISO40 / B18
- T-nuts
- expeller
- Adapter ISO40- MK 3 / MK 3-MK 2
- Coolant pump
- operating tool

Media informations ▼

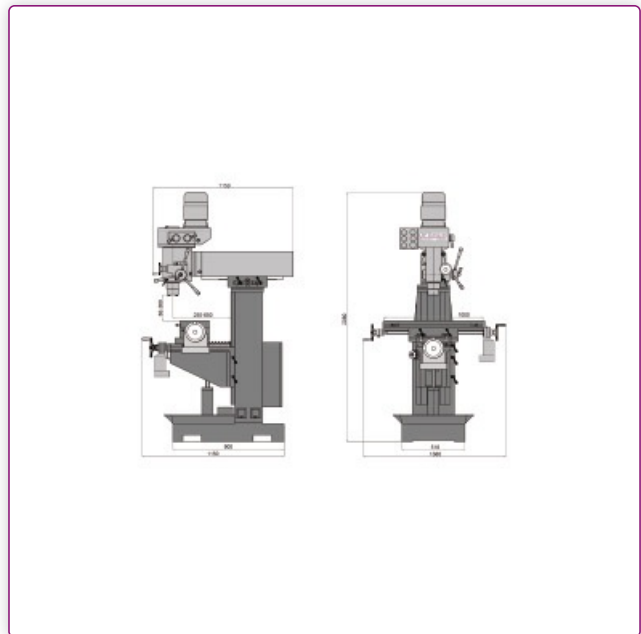

Technical data ▼

Dimensions and weights			
Length (product) approx.	1360 mm	Width/depth (product) approx.	1150 mm
Height (product) approx.	2080 mm	Net weight approx.	760 kg
Drilling/milling head			
Drill-mill head tilt range	$\pm 45^\circ$		
Drilling/milling output			

Drilling performance steel (S235JR)	30 mm	Max. size milling head	63 mm
Max. size shaft milling cutter	25 mm	Continuous drilling performance steel (S235JR)	25 mm
Electrical Data			
Drive motor output	0.75 / 1.5 kW	Supply voltage	400 V
Mains frequency	50 Hz		
Milling table horizontal			
Horizontal milling table length	1000 mm	Horizontal milling table width	240 mm
Min. clearance vertical spindle - horizontal milling table	60 mm	Max. clearance vertical spindle - horizontal milling table	360 mm
Horizontal milling table T-groove size	14 mm	Horizontal milling table T-groove number	4
Horizontal milling table rotation	± 45 °	Horizontal milling table max. load bearing capacity	150 kg
Cooling lubricant system			
Coolant pump(s) drive power	40 W		
Travel			
Travel X axis manual	580 mm	Travel Y axis manual	230 mm
Travel Z axis manual	320 mm	Travel X axis automatic	500 mm
Travel Y axis automatic	150 mm		
Vertical spindle			
Vertical spindle reach	250 – 650 mm	Vertical spindle spindle chuck	SK 40 DIN 2080
Vertical spindle speed range	115 – 1750 min ⁻¹	Vertical spindle number of gears	8
Vertical spindle quill stroke	120 mm	Vertical spindle tightening bar	M16
Vertical spindle drive motor output normal operation	0.85 / 1.5 kW		

Accessories ▼



Parallel spacer kit

20 parts

Article number ▼

3354001

OPTIMUM[®]
MASCHINEN - GERMANY



Parallel spacer kit

BT 40

Article number ▼

3536191

OPTIMUM[®]
MASCHINEN - GERMANY



Horizontal-vertical rotary indexing table

RT 150

Quality round table made of high-quality Meehanite cast

Article number ▼

3356150

OPTIMUM[®]
MASCHINEN - GERMANY



Horizontal-vertical rotary indexing table

RT 200

Quality round table made of high-quality Meehanite cast

Article number ▼

3356200

OPTIMUM[®]
MASCHINEN - GERMANY



Horizontal-vertical rotary indexing table with 3-jaw chuck

RTE 165

Quality round table made of high-quality Meehanite cast

Article number ▼

3356365

OPTIMUM[®]
MASCHINEN - GERMANY



Horizontal-vertical rotary indexing table with 3-jaw chuck

RTU 165

Quality round table made of high-quality Meehanite cast

Article number ▼

3354165

OPTIMUM[®]
MASCHINEN - GERMANY



Clamping tool kit

SPW 12

Article number ▼

3352017

OPTIMUM[®]
MASCHINEN - GERMANY



End mill set

HSS, 12-piece

Article number ▼

3352250

OPTIMUM[®]
MASCHINEN - GERMANY



End mill set

HSS, 20-piece

Article number ▼

3352255

OPTIMUM[®]
MASCHINEN - GERMANY



Workpiece support

WPS-4

Adjustment range 140 - 230 mm

Article number ▼

3354264

OPTIMUM®
MASCHINEN - GERMANY



Mandrel for drill chuck

cone outside ISO 40 / M16 / B16

Article number ▼

3352070

OPTIMUM®
MASCHINEN - GERMANY



Collet chuck set

ISO 40 / ER32 - M16 / BT40

Article number ▼

3352056

OPTIMUM®
MASCHINEN - GERMANY



Copy and face cutter head

Shaft ISO 40

Article number ▼

3350216

OPTIMUM®
MASCHINEN - GERMANY



Boring Drill Bit Set

Boring Drill Bit Set ISO 40

Article number ▼

3352128

OPTIMUM®
MASCHINEN - GERMANY

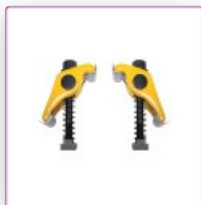

Down device

Table groove 14 mm / M 12

Article number ▼

3352031

OPTIMUM®
MASCHINEN - GERMANY



Precision machine vice

FMS 125

Article number ▼

3354125

OPTIMUM®
MASCHINEN - GERMANY



Precision machine vice

FMSN 125

Pull-down mechanism for secure clamping of the workpiece

Article number ▼

3354120

OPTIMUM[®]
MASCHINEN - GERMANY



Milling machine vise

VMQ 100

Robust design for milling, drilling and grinding

Article number ▼

3354181

OPTIMUM[®]
MASCHINEN - GERMANY



Three axis vise

MV3-75

Horizontal swivel movement up to 90 °

Article number ▼

3354175

OPTIMUM[®]
MASCHINEN - GERMANY



Three axis vise

DAS 100

Article number ▼

3355500

OPTIMUM[®]
MASCHINEN - GERMANY



Two axis vise

ZAS 50

Article number ▼

3354170

OPTIMUM[®]
MASCHINEN - GERMANY



Horizontal-vertical rotary indexing table

RT 100

Quality round table made of high-quality Meehanite cast

Article number ▼

3356110

OPTIMUM[®]
MASCHINEN - GERMANY



Twist Drill Set
25 pieces, 1 - 13 mm

Article number ▼
3201010

OPTIMUM®
MASCHINEN - GERMANY



Twist Drill Set
41-piece, 6 - 10 mm (0.1 mm rising)

Article number ▼
3201021

OPTIMUM®
MASCHINEN - GERMANY



Milling set
carbide, 18-piece

Article number ▼
3352118

OPTIMUM®
MASCHINEN - GERMANY



Milling set
radius, 9-piece

Article number ▼
3352116

OPTIMUM®
MASCHINEN - GERMANY



Edge finder
Diameter 10 mm

Article number ▼
3351171

OPTIMUM®
MASCHINEN - GERMANY



Precision quick-action drill chuck
1-10 mm, B16

Article number ▼
3050610

OPTIMUM[®]
MASCHINEN - GERMANY



Keyless drill chuck
DKC13 1-13 mm

Article number ▼
3050632

OPTIMUM[®]
MASCHINEN - GERMANY



Keyless drill chuck
DKC16 1-16 mm

Article number ▼
3050633

OPTIMUM[®]
MASCHINEN - GERMANY



Mandrel for drill chuck
Cone outside MK 2 / M10 / B16

Article number ▼
3050670

OPTIMUM[®]
MASCHINEN - GERMANY



Mandrel for drill chuck
Cone outside MK 4 / M16 / B16

Article number ▼
3350304

OPTIMUM[®]
MASCHINEN - GERMANY



Collet set
ER 32, Ø 1 - 16 mm

Article number ▼
3441122

OPTIMUM[®]
MASCHINEN - GERMANY



Stop angle
90 degrees

Article number ▼
3385052

OPTIMUM[®]
MASCHINEN - GERMANY



Tapping attachment
M5 - M12 / B16

Built-in fast reverse, immediately effective when changing the feed direction

Article number ▼
3352042

OPTIMUM[®]
MASCHINEN - GERMANY



T-nut
M 12/14 mm

Article number ▼
3353025

OPTIMUM[®]
MASCHINEN - GERMANY



Precision machine foot
SEU1

Article number ▼
3352985

OPTIMUM[®]
MASCHINEN - GERMANY



Vibration damper machine foot
SE 85

Article number ▼
3352982

OPTIMUM[®]
MASCHINEN - GERMANY



Leveling plate
SE 2

Article number ▼
3381016