

Upright drill

OPTIdrill D 26Pro

with V-belt drive

Article number ▼

3003030

Brand ▼

Optimum

Catalog directory ▼

Metalworking machines » Drilling machines

» Drilling machines with V-belt drive » OPTIdrill D

OPTIMUM[®]
MASCHINEN - GERMANY



Shipping informations ▼

Packaging Metrics		Weights		Delivery		Other	
Length	1,455 mm	Gross	71 kg	Delivery	Carrier	DualUse	✘
Width	550 mm	Net	68.5 kg	Content	4 pc(s).	SCIP	n/a
Height	270 mm					SVHC	No



Description ▼

- Industrial engine
- Easy to use safety switch according to IP 54
- Digital drilling depth and speed indicator integrated in the housing
- Separate emergency stop impact switch
- Precision Spindle bore
- Safety electronics in 24 V DC
- Guaranteed concentricity measured less than 0.02 mm in the drill quill
- Drill spindle with precision ball bearings
- High quality keyless chuck
- Depth stop
- Precision machined, stable drill table with diagonal T-slots and circumferential cooling water channel
- V-belt cover with safety switch
- One piece cast aluminum die-cast quill lever with softgrip handles
- Large, height-adjustable protective screen with safety switch
- Heavy version of the entire machine

From D 23 Pro

- GATES quality strap

From D 23 Pro / 400 V

- Forward / reverse operation

D 33Pro

- Massive, large base plate with T-slots, strongly ribbed on the back

Delivery content ▼

- Keyless chuck 1 - 16 mm
- Morse cone MK 3 / B16
- T-nuts

Media informations ▼



Belt drive

- High smoothness thanks to ground multi-tooth contact
- Best power transmission by aluminium pulleys in combination with toothed GATES quality wedge belts (from OPTIdrill D 23PRO)



Display

- Digital drilling depth and speed display integrated in housing
- Unit convertible metric / inch



Drilling table

- Precisely machined, stable drilling table with diagonally running T-slots and circumferential cooling water channel
- Laterally tiltable ± 45
- Rotatable 360

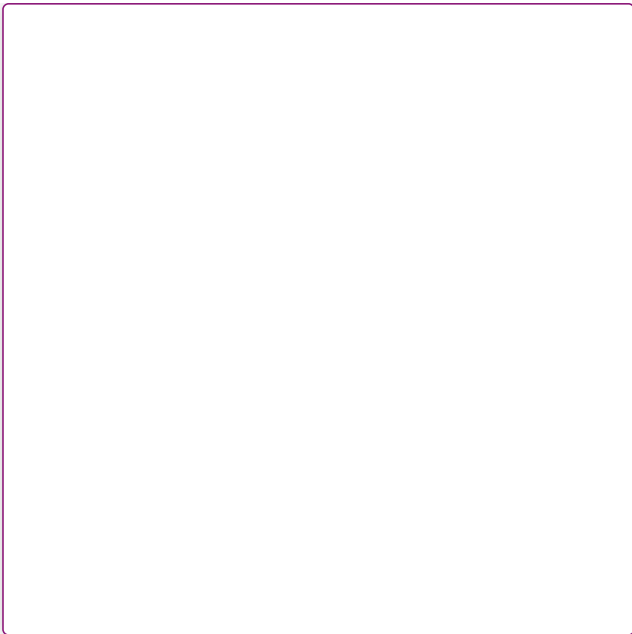

Motor

- Industrial motor

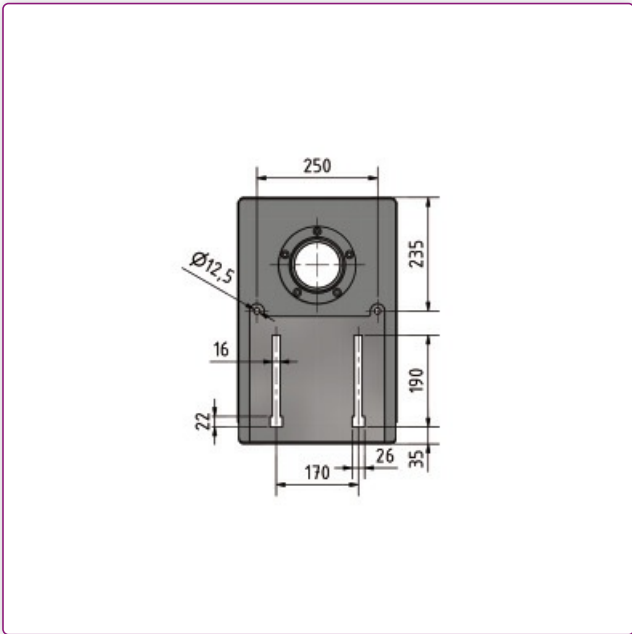
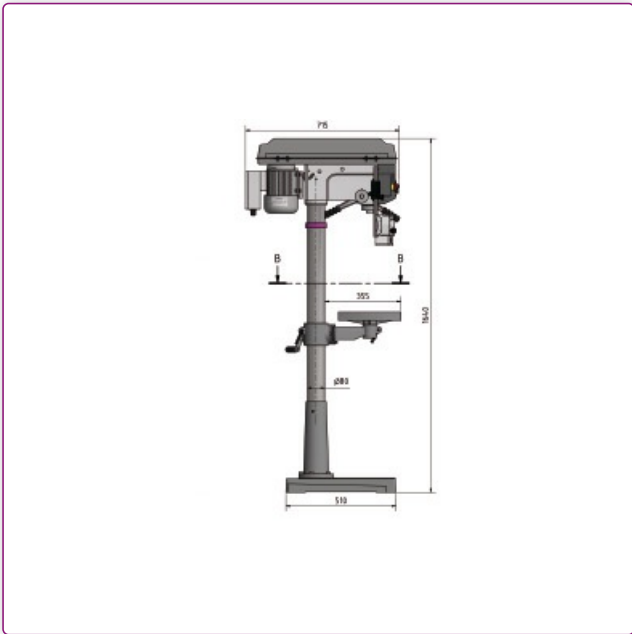

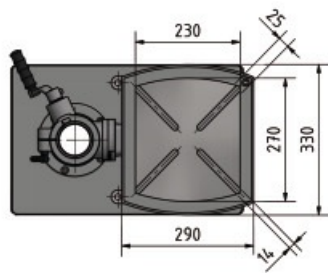

Technical data ▼

Dimensions and weights			
Column diameter	80 mm	Length (product) approx.	670 mm
Width/depth (product) approx.	355 mm	Height (product) approx.	1640 mm
Net weight approx.	85 kg		
Drilling performance			
Drilling performance steel (S235JR)	25 mm	Continuous drilling performance steel (S235JR)	20 mm
Drilling table			
Drilling table workspace length	330 mm	Drilling table workspace width	290 mm
Drilling table T-groove size	14 mm	Drilling table rotation	360 °
Drilling table angle	45 °	Max. distance spindle - drilling table	720 mm
Speed range			
Speed range	200 – 2440 min ⁻¹	Number of gears	12
Electrical Data			
Drive motor output	0,75 kW	Supply voltage	400 V
Mains frequency	50 Hz		
Machine base			
Max. distance spindle - machine base	1230 mm	Machine base workspace length	385 mm
Machine base workspace width	260 mm	Machine base T-groove size	16 mm
Machine base T-groove number	2	Machine base T-groove spacing	170 mm
Spindle			
Quill stroke	85 mm	Spindle chuck	MT 3
Reach	210 mm		

Accessories ▼



Twist drill HSS with Morse taper

MT 3

Article number ▼

3051003

OPTIMUM®
MASCHINEN - GERMANY