

B-Type Milling Vise

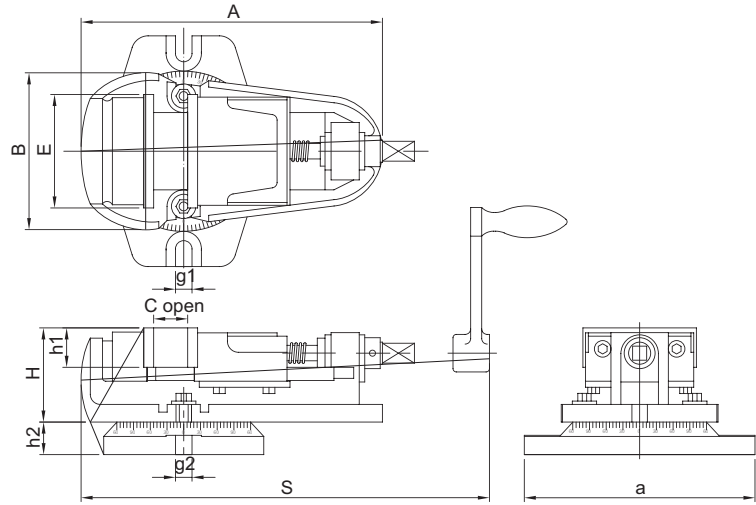
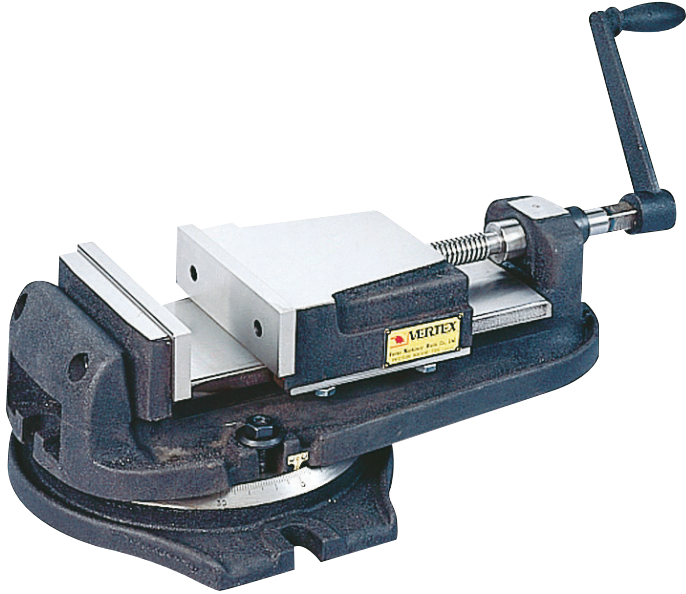

- A wider bottom to increase clamping force.
- Groove device to collect cutting oil.
- Full 360° swivel base with line, accurate graduation.
- In order to ensure the accuracy when using it' better that don't put swivel base together

ACCURACY
GUARANTEE

0.01/100 MM 0.02/50

TABLE
HARDNESS

BENDING
PROOF

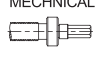
MECHANICAL

ORDER NO.	A	B	E	H	C OPEN	S	a	h1	h2	g1	g2	Max. Clamp Force (kgf)	G.W. kgs
VBV-6	452	218	160	103	132	483	317	48	40	16	16	1000	41