

VP-200 Ground Parallels

ORDER NO.VP-200 CODE NO.1004-085

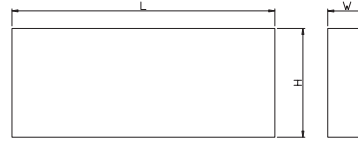

NEW



MADE OF HIGH GRADE ALLOY STEEL
HARDENED AND GROUND.
ACCURACY: 0.01/100 MM

- Hardness: HRC 48°-53°

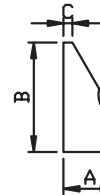
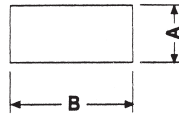

FOR OVER 150 m/m, 200m/m
JAW PLATE VISE USING

BODY SIZE	CLAMP SIZE
AxBxLxPcs	AxBxCxLxPcs
5x16x150x2	31x15x200x2x2.5
6x18x150x2	
8x24x150x2	
10x30x150x2	
12x36x200x2	
14x48x200x2	
18x60x200x2	
22x62x200x2	

Adjustable Angle Plate

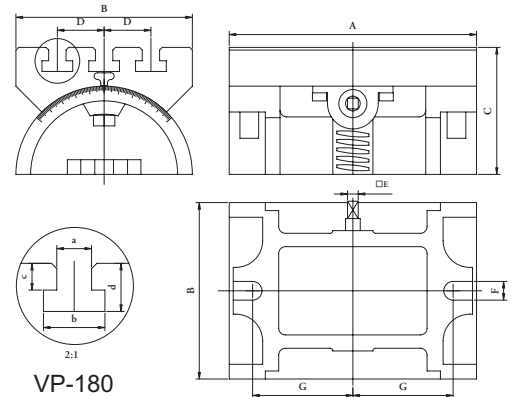

1. For angle setting on various machine tools.
2. Adjustable 45°
3. Material: FC25
4. Lower plate and bigger working space.

VP-180
VP-250
VP-380

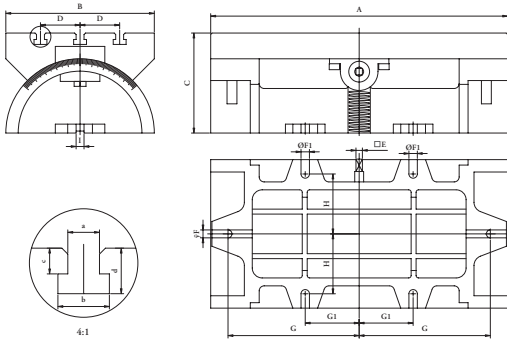

VP-600

Unit:mm

ORDER NO.	A	B	C	D	E	F	G	a	b	c	d	kg	CODE NO.
VP-180	185	132	95	35	8	14	75	13	23	10	18	7.38	1004-089
VP-250	255	180	136	50	10	16	95	16	26	13.5	25	28.7	1004-090
VP-380	380	255	181	69	13	18	150	16	26	14	25	56	1004-091

Unit:mm

ORDER NO.	A	B	C	D	E	F	F1	G	G1	H	I	a	b	c	d	kg	CODE NO.
VP-600	600	300	202	80	13	16	17	265	109	121	16	16	26	13	23	85	1004-092

Angle Plate With Swivel Base

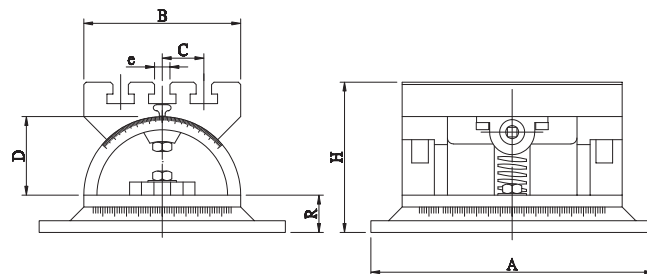
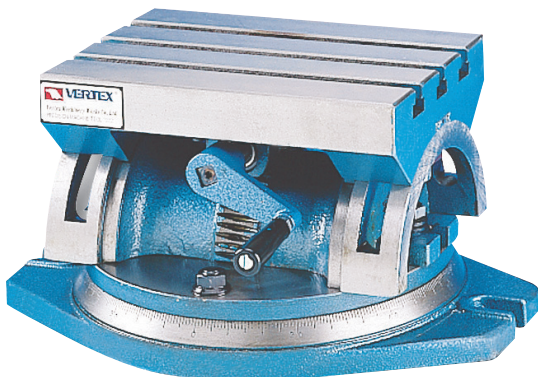

Unit:mm

ORDER NO.	Table LxW			T-SLOT			R	WEIGHT (kg)	CODE NO.
	A	B	H	e	C	D			
VP-250S	290	180	206	16	50	105	52	36	1004-100
VP-380S	390	360	255	16	68	127	60	86	1004-101

360° SWIVEL BASE.