



# Wheel Balancing Stand

ORDER NO.WBS-300 CODE NO.2014-001

WEIGHT:12.5kgs



MAX.WHEEL DIAMETER ALLOWED Ø 500mm

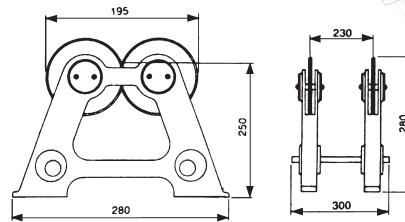

The stand is specifically designed to improve accuracy and longer life for grinding. It is finished with cast iron and fine through hardened to HRC55°.



# Level Balancing Stand

ORDER NO.LBS-100

CODE NO.2014-010

WEIGHT:8.8kgs

ORDER NO.LBS-350

CODE NO.2014-011

WEIGHT:15.1kgs



( )For LBS-350

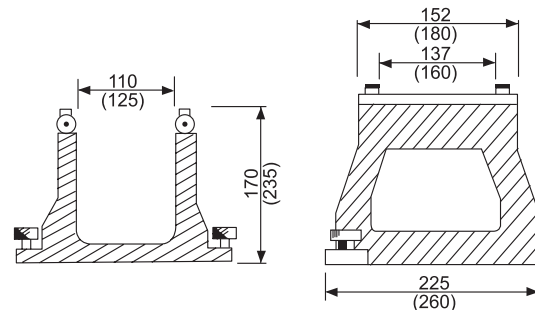

This machine encloses minute leveling instrument. The adjustment of horizontal enable rapidly and accurately.

MAX.WHEEL DIAMETER ALLOWED Ø200mm, Ø350mm



# Driving Carrier

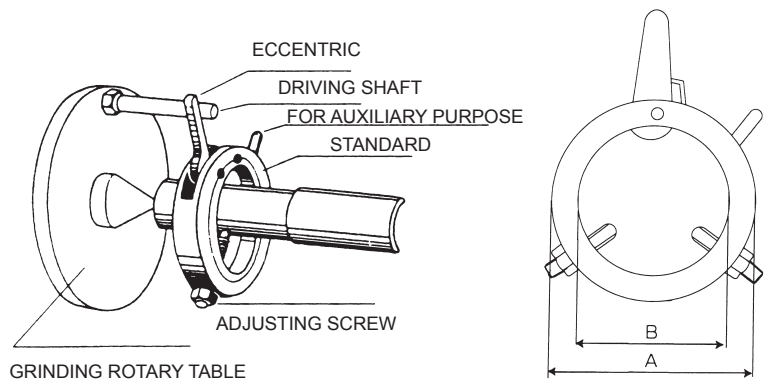
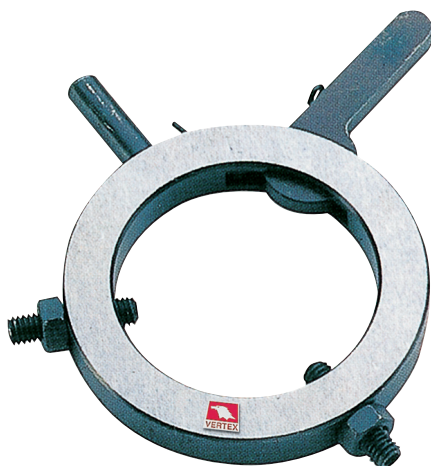

## FEATURES:

- SUITABLE FOR GRINDING OF SHAFTS.
- EASY ATTACH AND DETACH BY ONE HAND.

ORDER NO	CAPACITY	A	B	WEIGHT (kg)	CODE NO.
VDC-13	Ø6~Ø14	36	18	0.1	2014-020
VDC-22	Ø13~Ø24	48	28	0.2	2014-021
VDC-30	Ø20~Ø33	58	38	0.2	2014-022
VDC-40	Ø31~Ø42	68	48	0.2	2014-023
VDC-50	Ø36~Ø50	78	58	0.3	2014-024
VDC-60	Ø40~Ø62	89	68	0.3	2014-025
VDC-80	Ø60~Ø80	119	88	0.6	2014-026
VDC-100	Ø80~Ø100	140	109	0.7	2014-027